



SWITCH CAP  
P/N:SC227



Materials

ABS

Color

Black , Chrome Cladding  
(OEM AVAILABLE)

Packaging

Bulk Package

Inner Package: Plastic bag

Outer Package: Carton

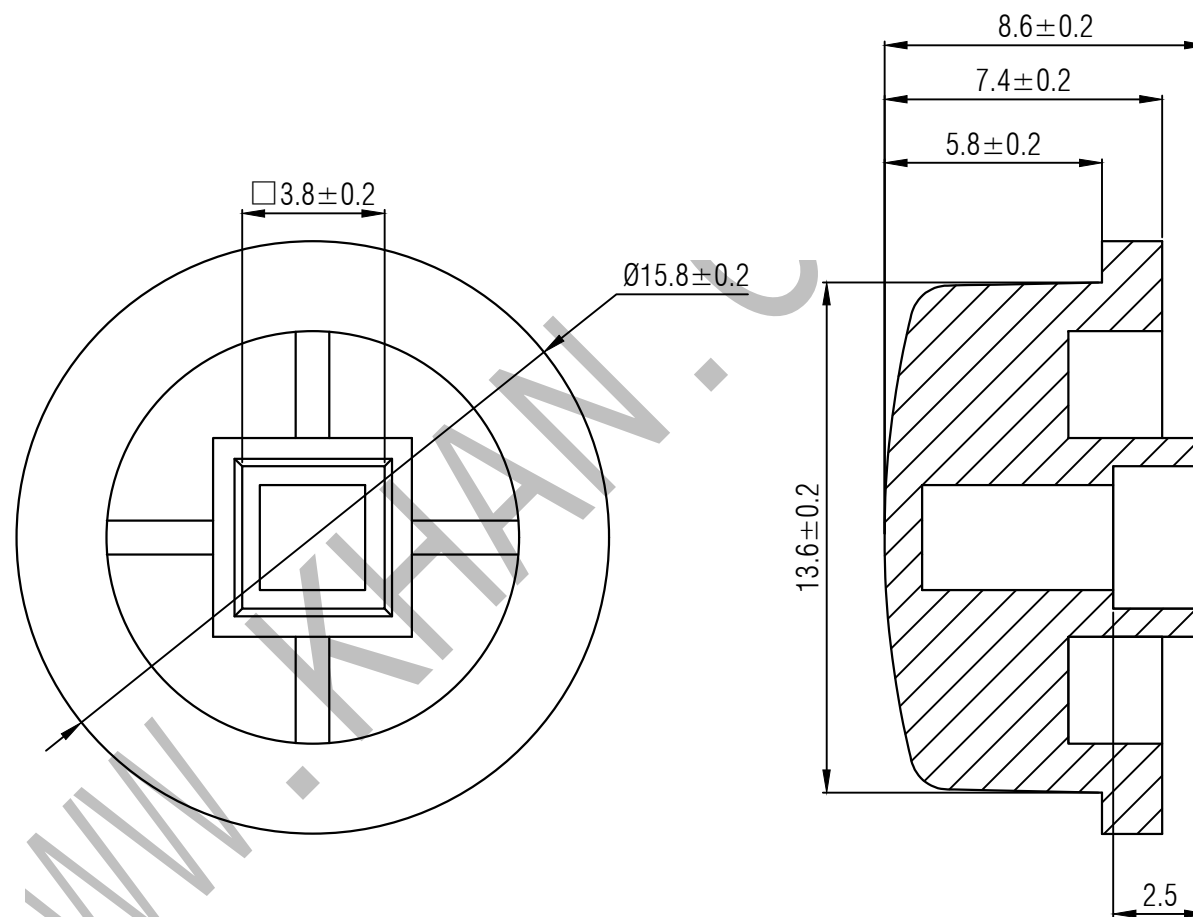

KANGHONG ELECTRONIC

VERSION

KH14FE22E

PROJECTION



Dimensions are shown:mm(inches)

SCALE

5:1

SIZE

A4

2014.02.20

DESIGN

DRAWN

APPROVAL